

FRONT: 0.78m
SIDE: 0.78m
HEIGHT: 1.80m

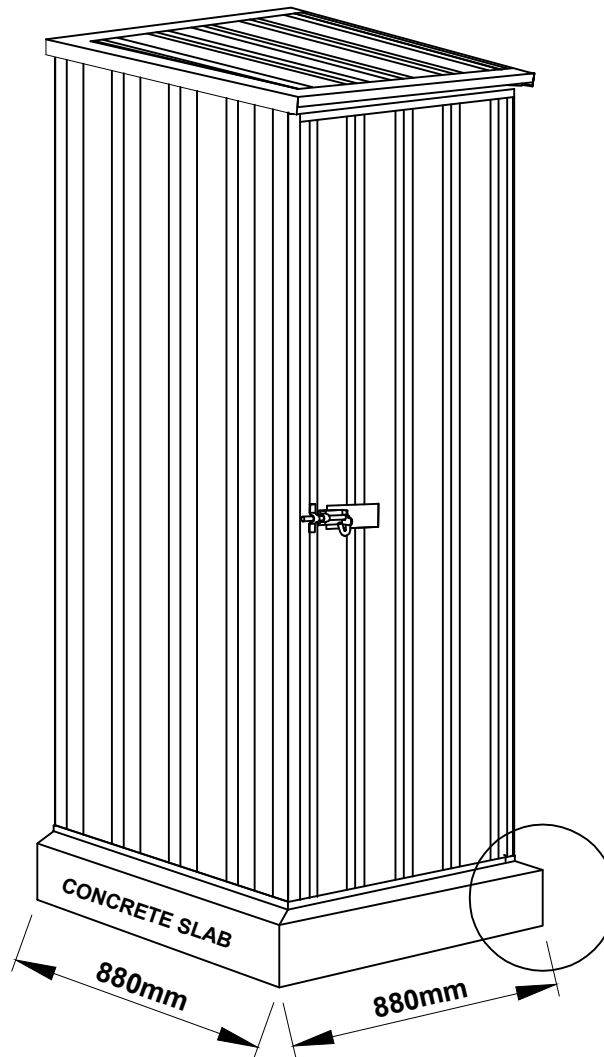

Quality
Endorsed
Company
ISO9002
LIC NO. 155
STANDARDS AUSTRALIA

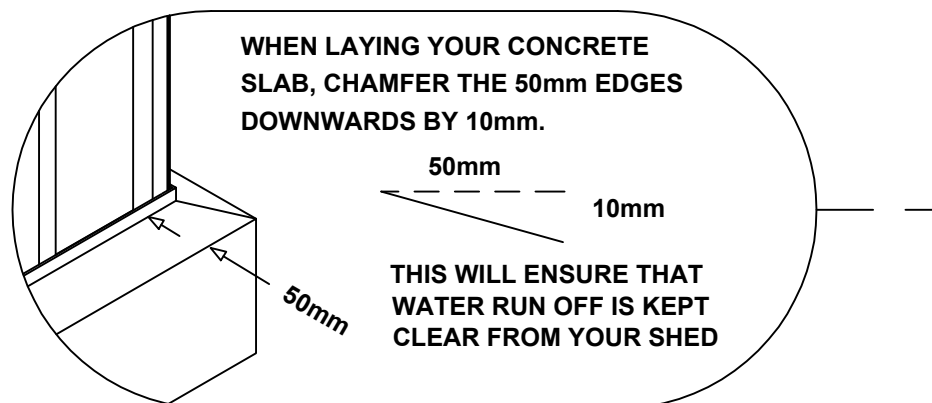

We thank you for choosing an Australian Made Shed.

At ABSCO Industries we are always looking to be number ONE, so please let us know what you think of our instructions. Feedback makes us better.
feedback@absco.com.au

GENERAL INSTRUCTIONS

- Before commencing any assembly, read through these instructions in detail to gain a thorough understanding of assembly methods and associated details.
- Unpack the carton and carefully identify and check off all the parts against the parts described and illustrated on pages three and four.

SITE PREPARATION

- The site for the shed must be level.
- It is recommended that the shed be set on a 100mm concrete slab and anchored down appropriately (refer page 16 for details).
- Anchor sets are not supplied as standard items with this product.

TOOLS REQUIRED



3mm
4mm

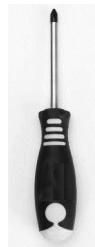



OPTIONAL

A NOTE ON SAFETY





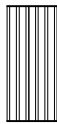
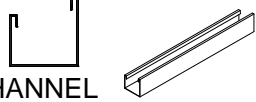

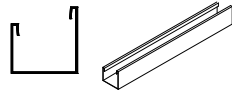
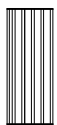
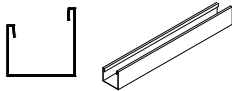
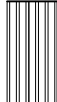
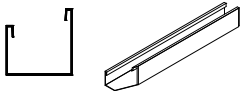
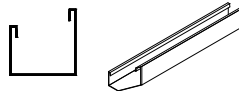
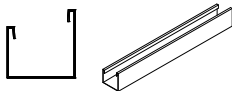
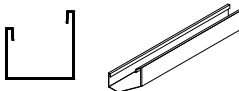
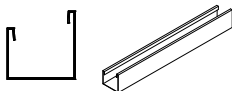
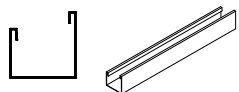
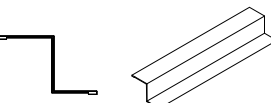
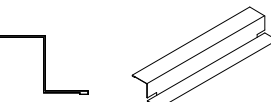
- Some parts may have sharp edges. It is advisable to wear gloves when handling these items and safety glasses if drilling holes. Sensible shoes are highly recommended.
- Do not erect your shed in windy conditions, ensure that the shed is securely anchored to a solid foundation immediately after construction is completed.
- It is highly recommended to erect the shed with two or more people.

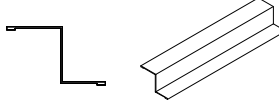
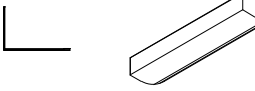
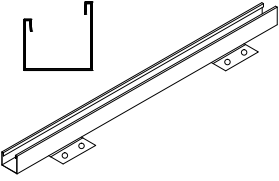
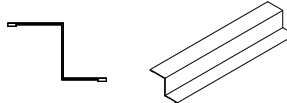

COMPONENTS PACKING LIST - CHECK OFF ALL COMPONENTS

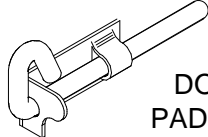
QTY	COMPONENT DESCRIPTION	PART No.	CHECK	QTY	COMPONENT DESCRIPTION	PART No.	CHECK
2	 STEEL SHEET 1785mm X 773mm	30E		2	 CHANNEL L = 773mm	58C	
1	 STEEL SHEET 852mm X 773mm	43T		1	 CHANNEL L = 720mm	54G	
1	 STEEL SHEET 1785mm X 773mm	30F		2	 CHANNEL L = 773mm	81J	
1	 DOOR SHEET 1725mm X 711mm	37A		2	 CHANNEL L = 1785mm	80A	
2	 CHANNEL L = 766mm	54H		1	 CHANNEL L = 1725mm	58B	
2	 CHANNEL L = 773mm	54F		2	 CHANNEL L = 712mm	58M	
2	 CHANNEL L = 773mm	61E		1	 JAMB L= 1785mm	89A	
				1	 JAMB L= 1785mm	89B	

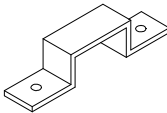
COMPONENTS PACKING LIST - (CONT.) CHECK OFF ALL COMPONENTS

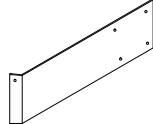
QTY	COMPONENT DESCRIPTION	PART No.	CHECK	QTY	COMPONENT DESCRIPTION	PART No.	CHECK
1	 JAMB L= 720mm	91D		2	 LIP TRIM L= 852mm	88L	
1	 DOOR TRIM SIDE CHANNEL WITH HINGES FITTED L = 1725mm	58A		2	 JAMB L= 1080mm	91E	
CONTENTS OF FITTINGS PACKET							
120	 SELF TAPPING SCREWS 10mm			1	 DOOR PADBOLT	22A	
6	 4mm CSK SCREW & NUT SECURE HINGES TO DOOR			1	 DOOR PADBOLT HASP		
12	 SELF TAPPING SCREWS 20mm REFER TO PAGE 15			6	 3mm POP RIVETS SECURE HINGES TO DOOR (ALTERNATIVE FIXING METHOD)		
1	ASSEMBLY INSTRUCTIONS			1	 DOOR STRAP L: 165mm	12A	

VIEW OF ROOF COMPONENTS

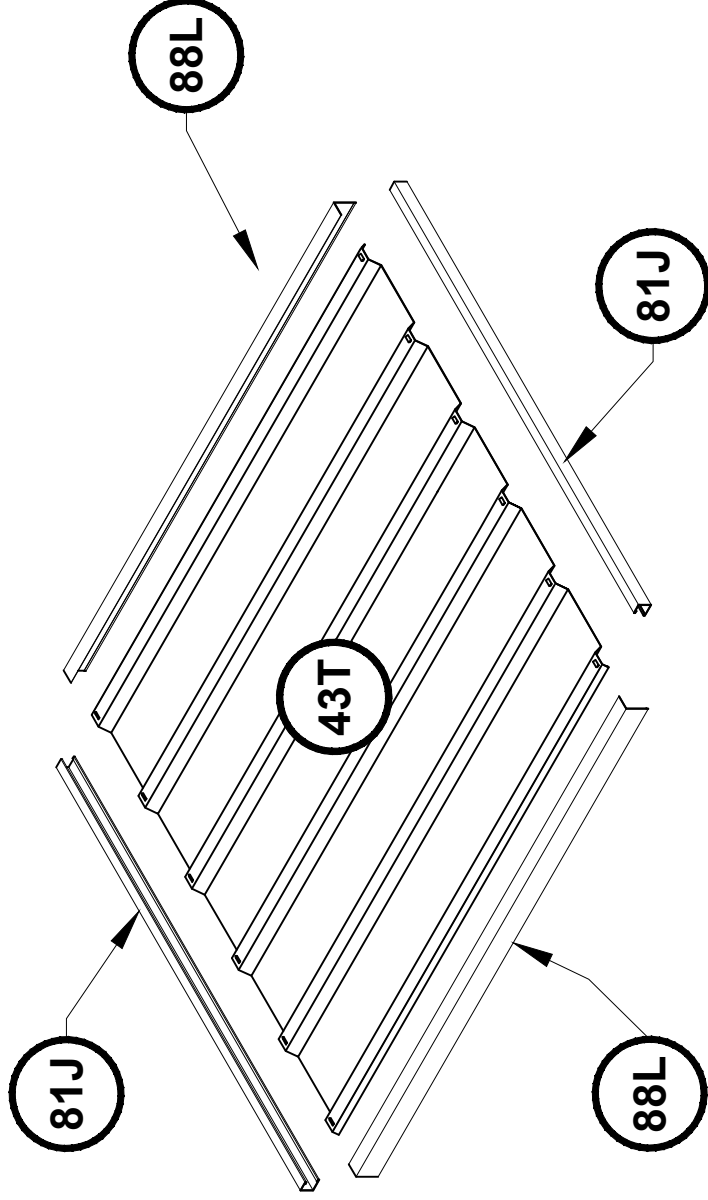

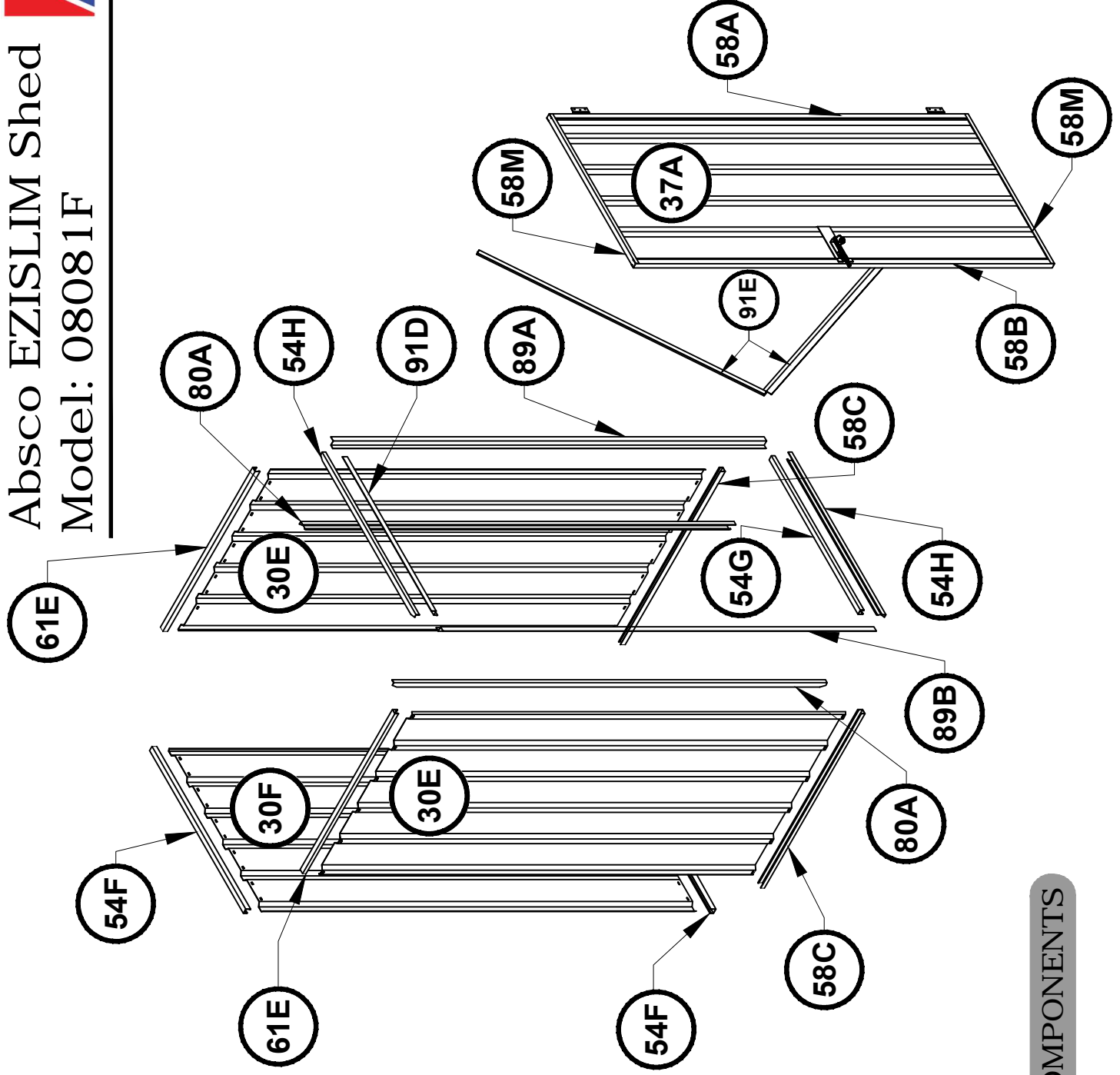

VIEW OF WALL COMPONENTS

ABSCO ASSEMBLY INTRODUCTION

The snap-tite assembly system locks most perimeter channels to all roof and wall sheets without the need for tools and fasteners. The front door frame and door assembly will require 3mm holes to be drilled where necessary.

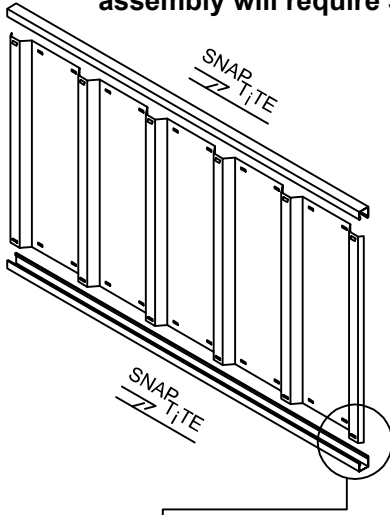

To pre-assemble the four wall panels and two roof panels, the perimeter channels are secured to the top and bottom of each panel using the snap-tite system, as detailed on the following pages wherever you see the symbol.

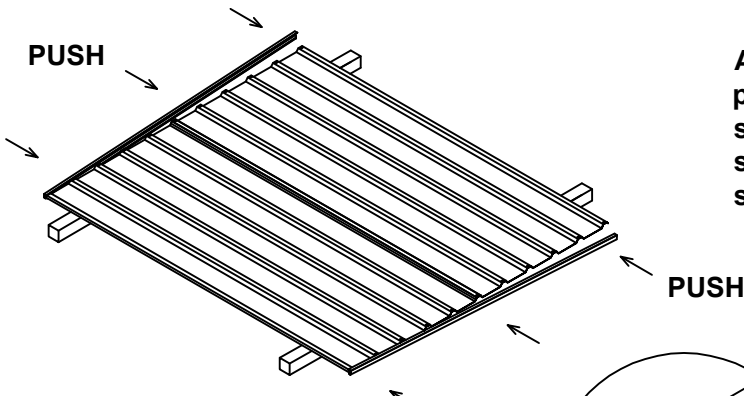
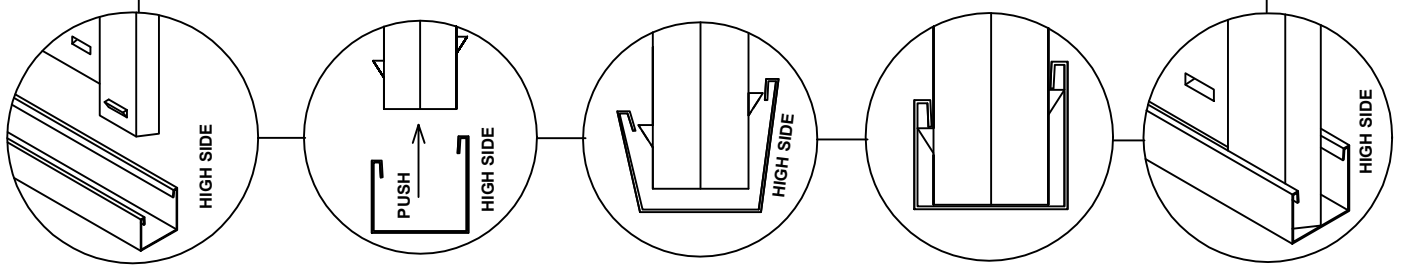
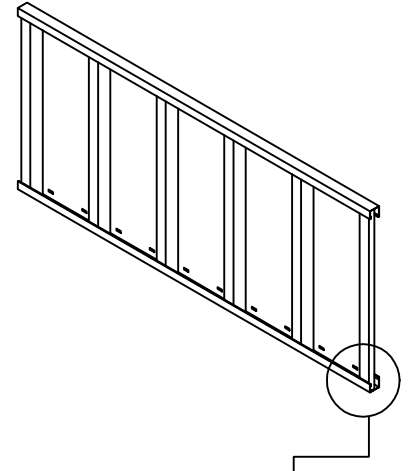

After joining sheets together, position channel over one end of the sheets, gently tapping it over the snap-tite lugs, working along the sheets to the other end.

Position sheets on timbers, trestles or partly over edge of concrete slab.

Each perimeter channel must finish flush with the edges of the sheets. the snap-tite system allows adjustment for this process by simply tapping the channel along the sheets until each end is neatly flush.

FASTENING SYMBOLS

 Join components together with one screw at this location only, as some channel sections have extra holes that are not required for this model of garden shed

 3mm POP RIVETS

 4mm NUT & BOLT SET

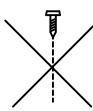
 Do not join components together at this location yet, as the screw may obstruct further assembly of other components

SIDE PANEL ASSEMBLY

LEFT SIDE PANEL

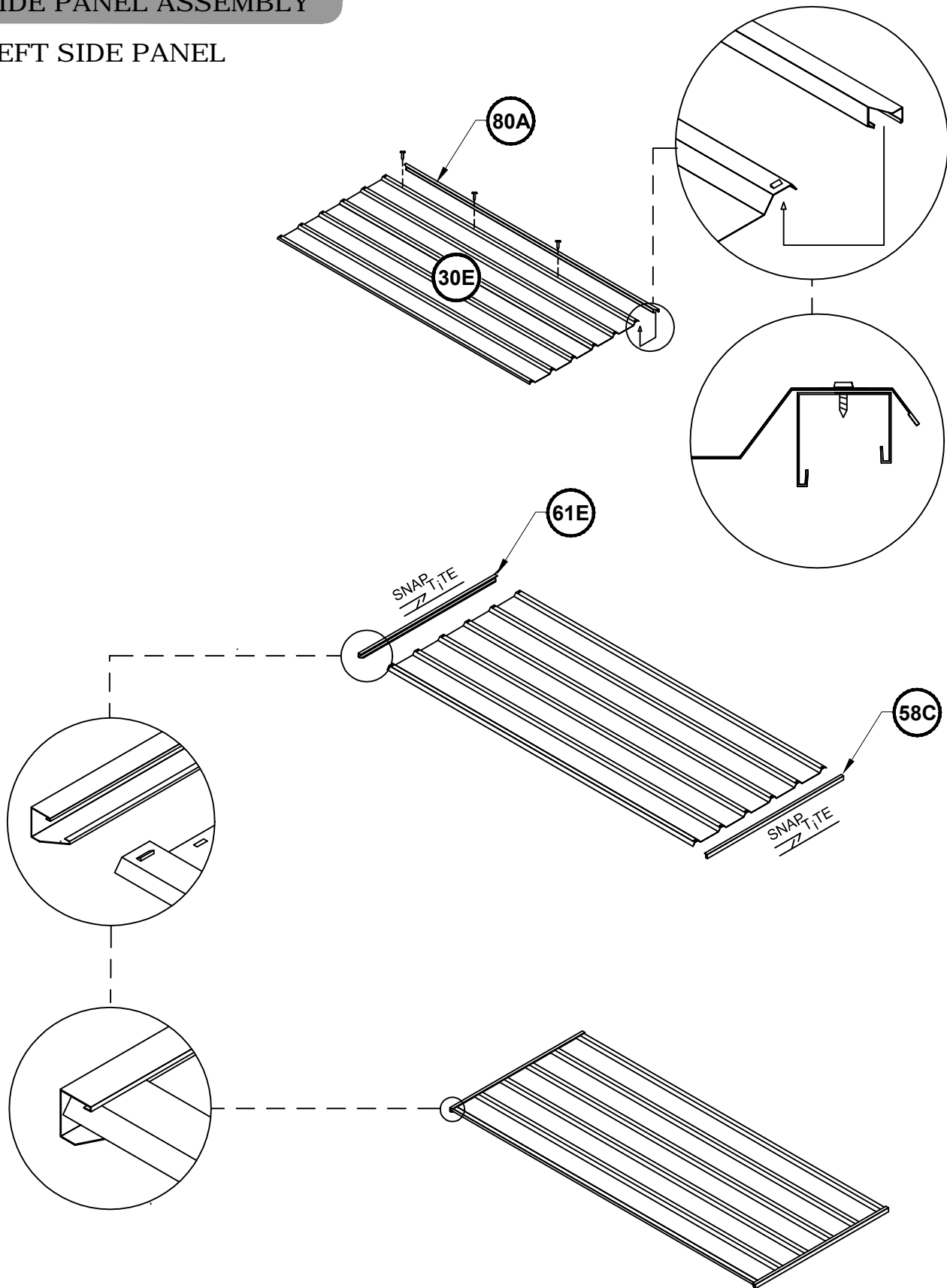

SIDE PANEL ASSEMBLY

RIGHT SIDE PANEL

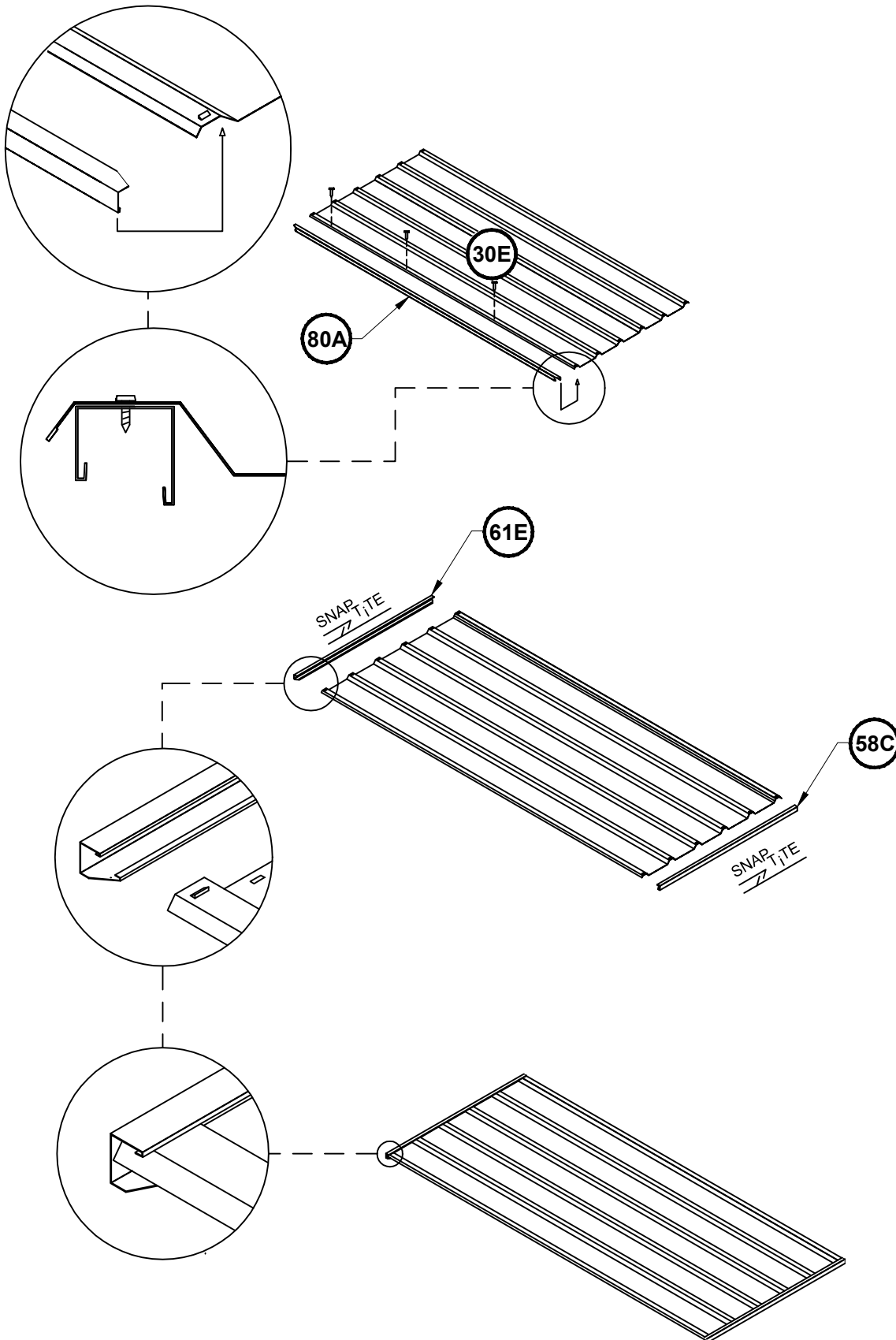

REAR PANEL ASSEMBLY

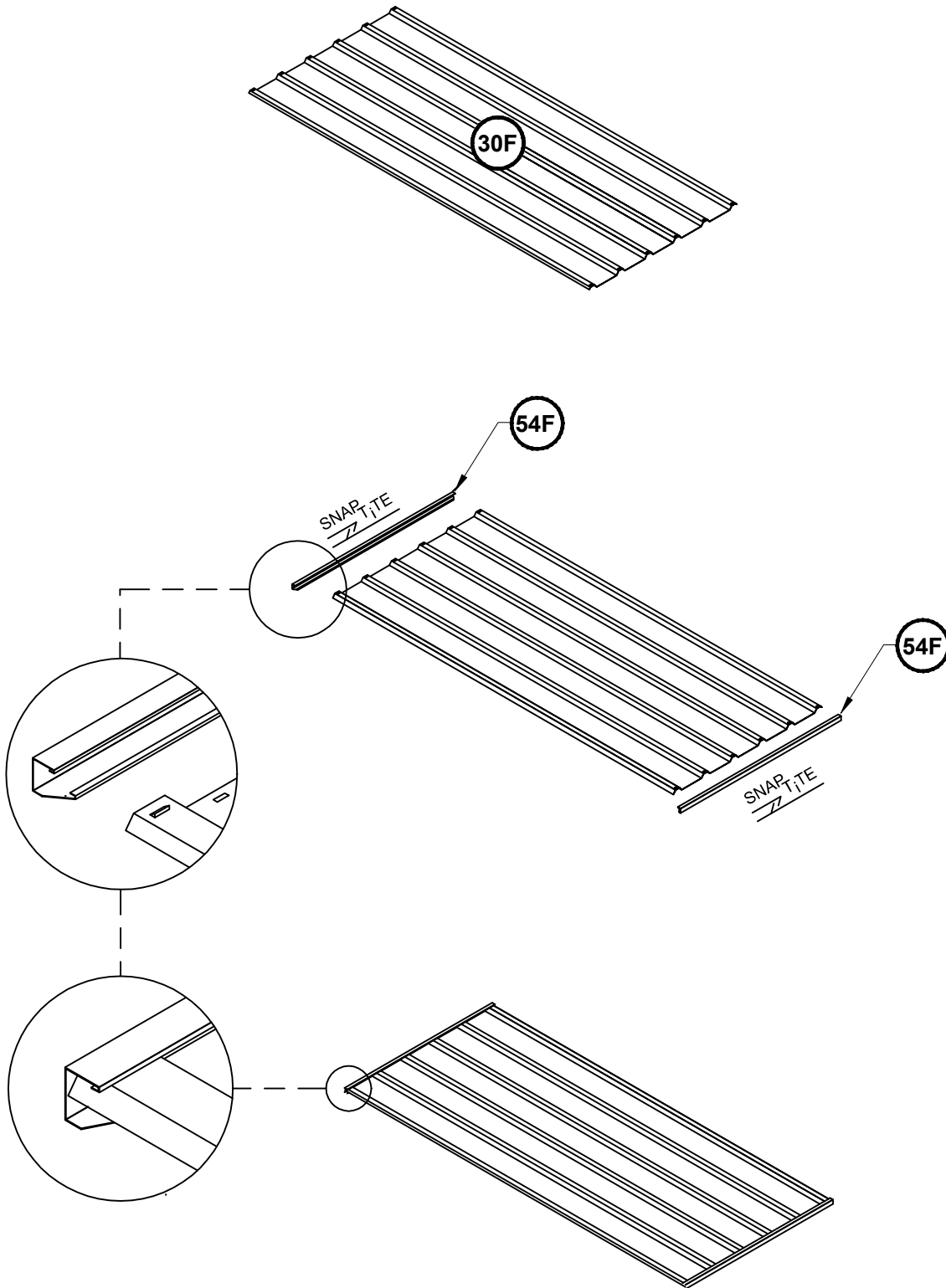

ROOF PANEL ASSEMBLY

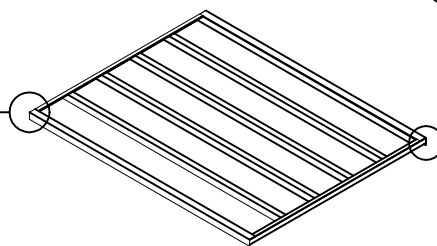
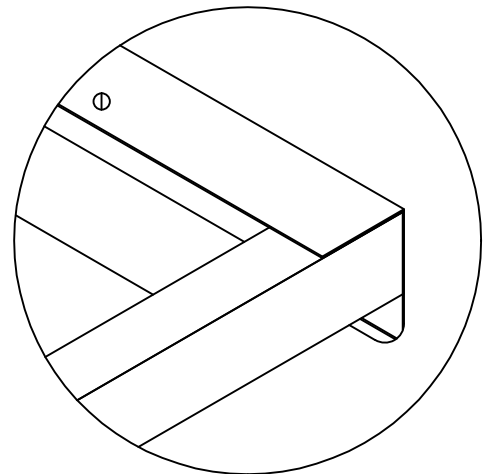
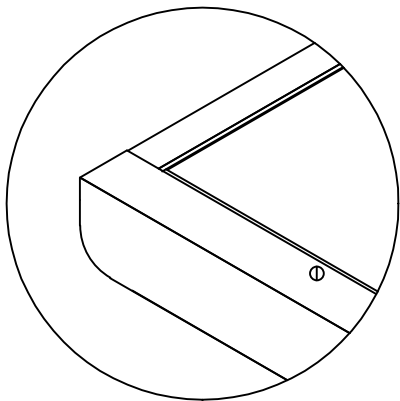
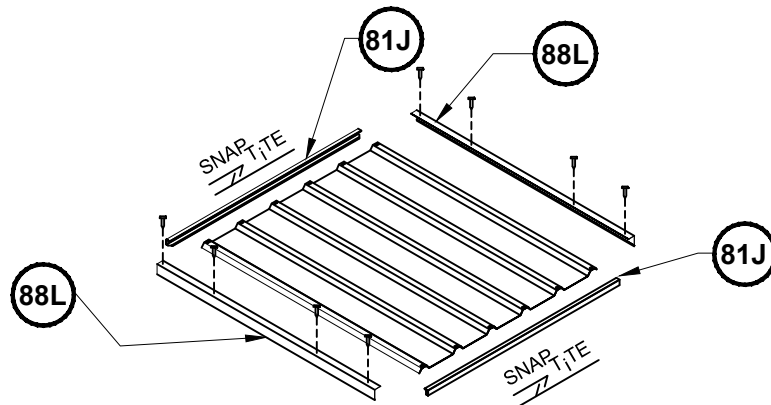
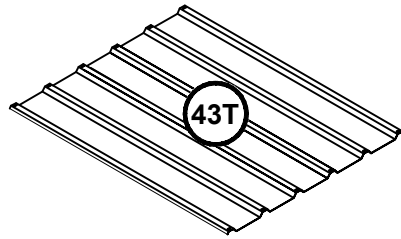

FRONT FRAME ASSEMBLY

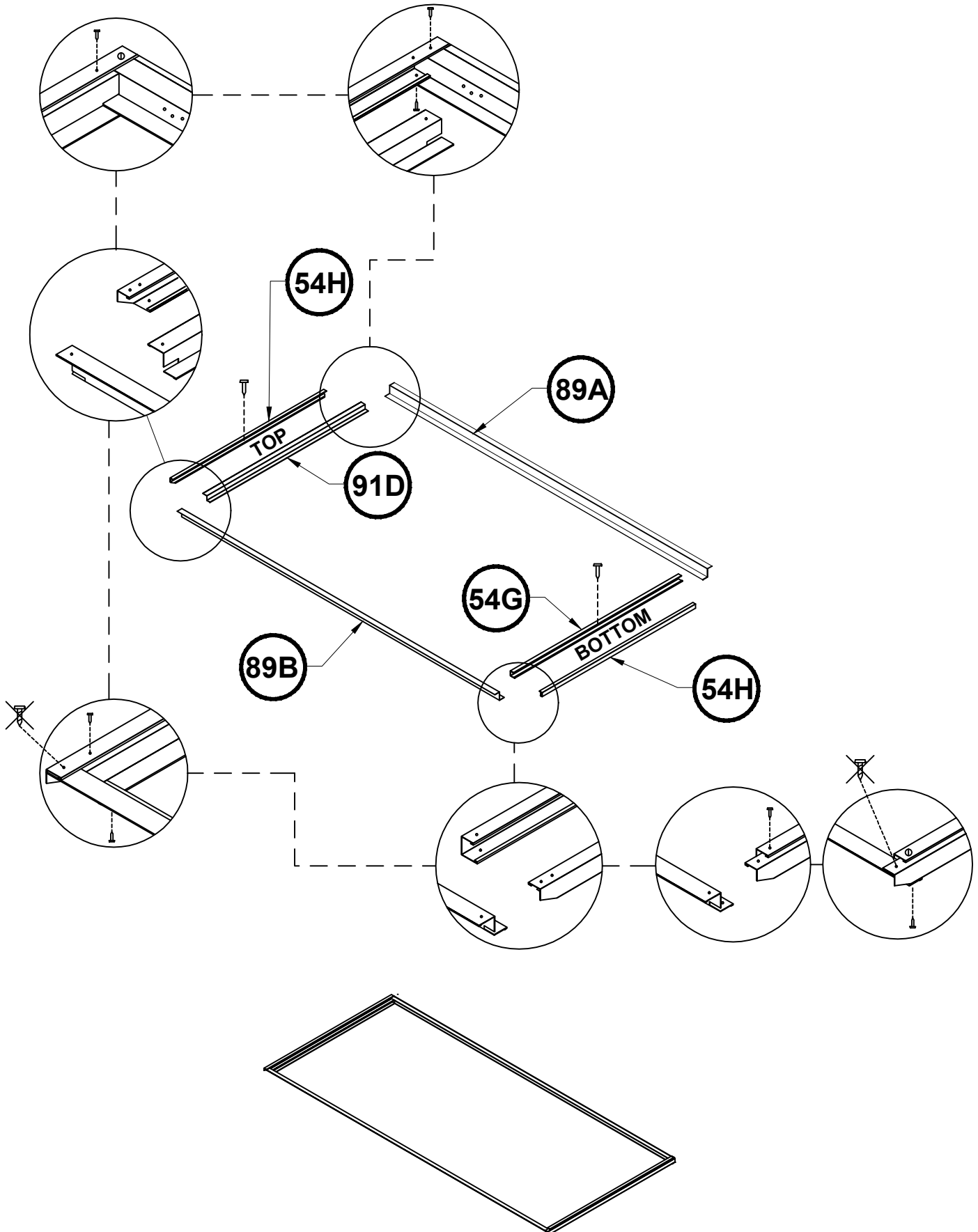

DOOR PANEL ASSEMBLY

NOTE: THIS SHEET (37A) IS 711mm WIDE BY 1725mm HIGH

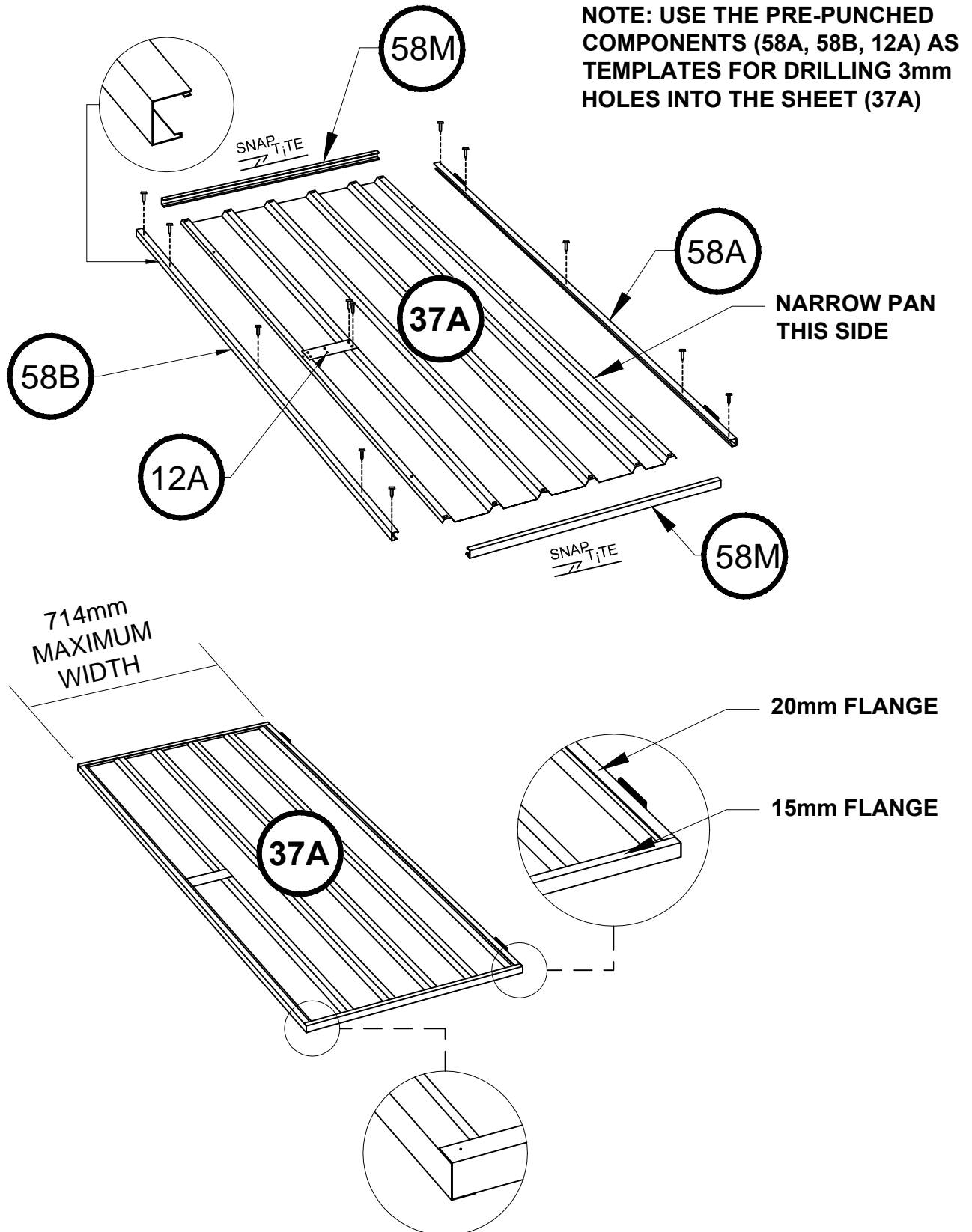

FRONT PANEL AND DOOR CONNECTION
ASSEMBLY PHOTOS

CORNER DOOR JAMB ASSEMBLY



DOOR CONNECTION & JAMB ASSEMBLY



PADBOLT & HASP CONNECTION



PADBOLT TO DOOR CONNECTION



DOOR BRACE CONNECTION

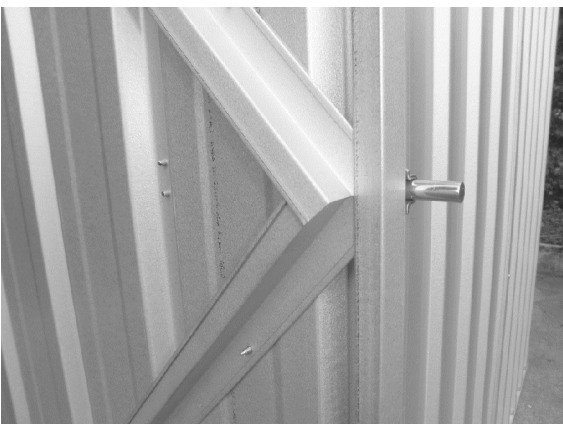

NOTE: PLEASE REFER TO
THE FOLLOWING PAGES
FOR FURTHER DETAIL

PANEL CONSTRUCTION

NOTE: Take care to ensure that both front and rear wall panels are not positioned upside down. The top channel of each panel is pre-punched for attaching roof sheets. The base channels are not pre-punched.

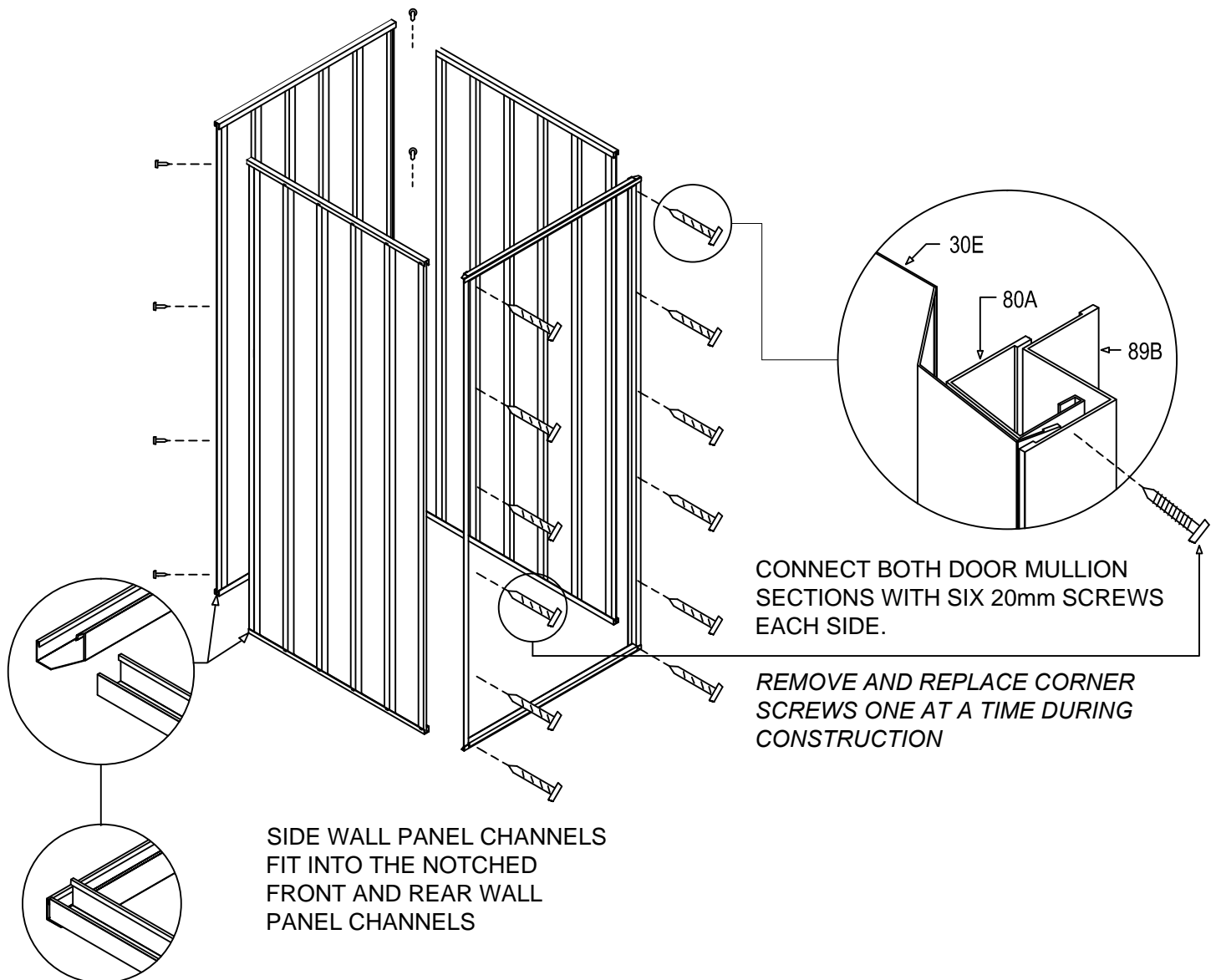

ROOF CONSTRUCTION AND ANCHORING OF SHED

NOTE: IT IS IMPORTANT TO COMPLETE THE STEPS ON THIS PAGE BEFORE PROGRESSING ANY FURTHER

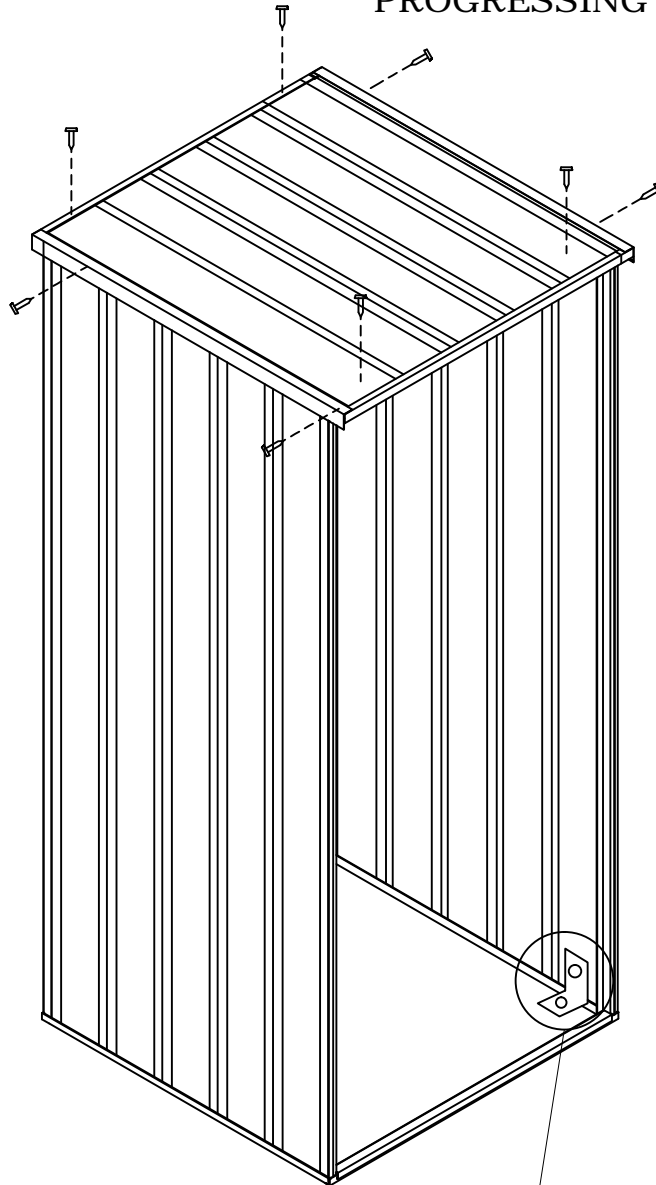

ANCHORING OF SHED

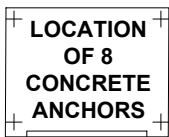

- EACH ANCHOR CONSISTS OF ONE NUT, BOLT, DYNABOLT AND STEEL ANGLE
- DRILL A 10mm HOLE INTO THE WALL SHEET
- DRILL A 10mm HOLE INTO THE CONCRETE

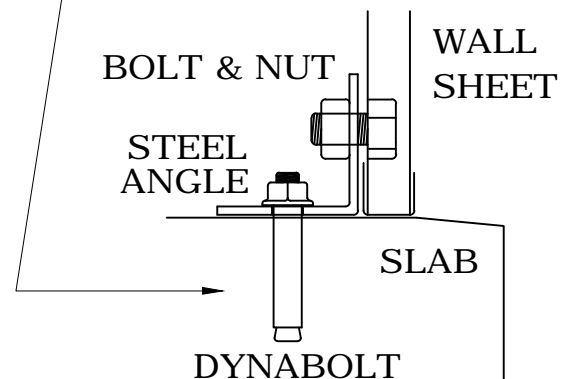

DOOR PANEL ASSEMBLY

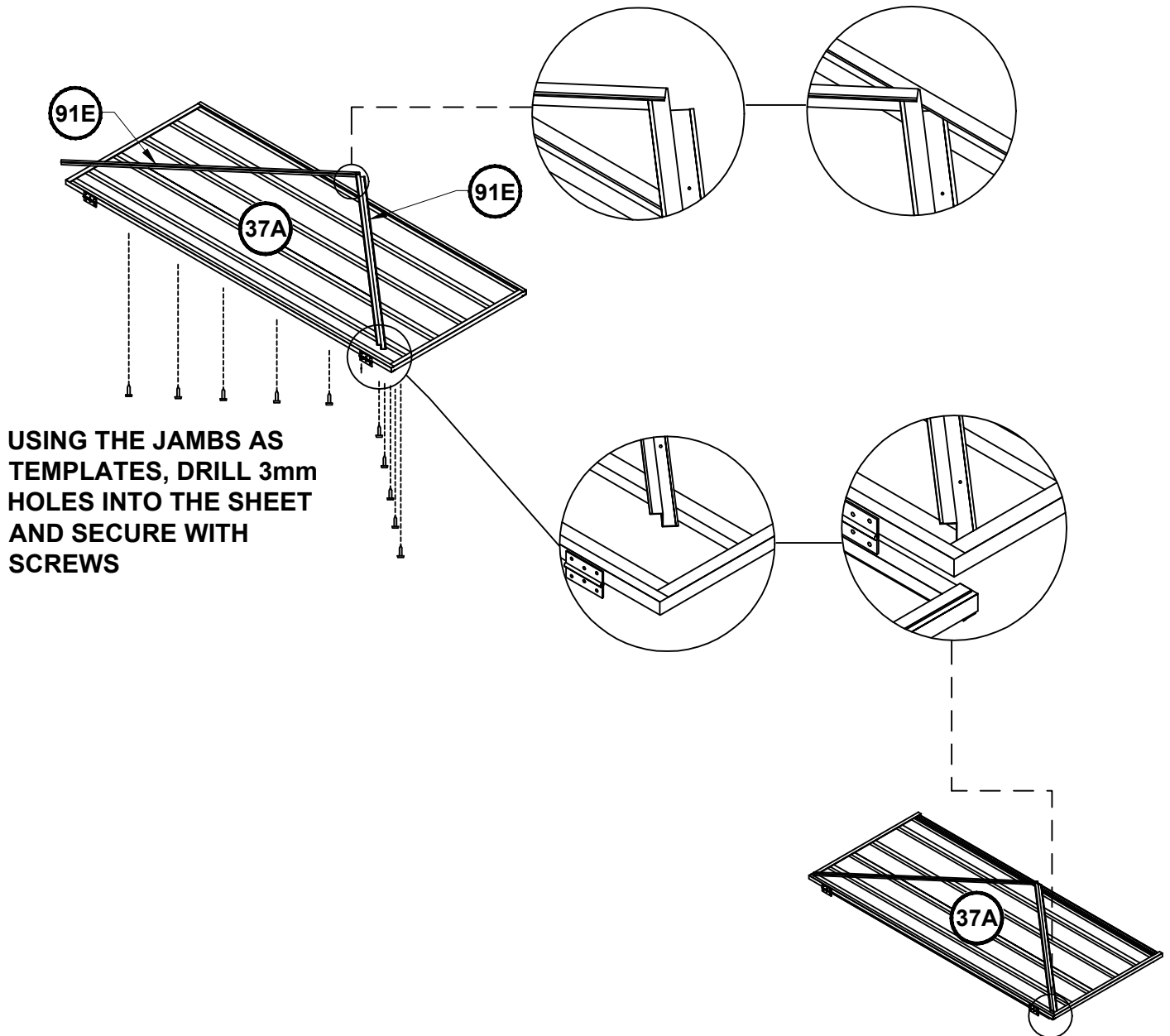

FINAL CONSTRUCTION

CONNECT DOOR TO FRONT FRAME

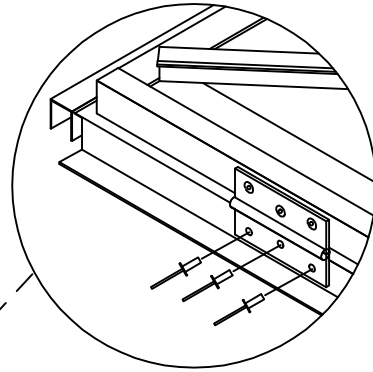

NOTE: NUTS AND BOLTS (SUPPLIED) MAY BE USED INSTEAD OF POP RIVETS (SUPPLIED) BY SIMPLY ENLARGING THE HINGE HOLE SETS IN THE JAMB USING A 4MM DRILL BIT

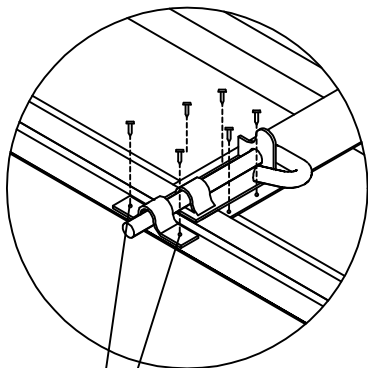
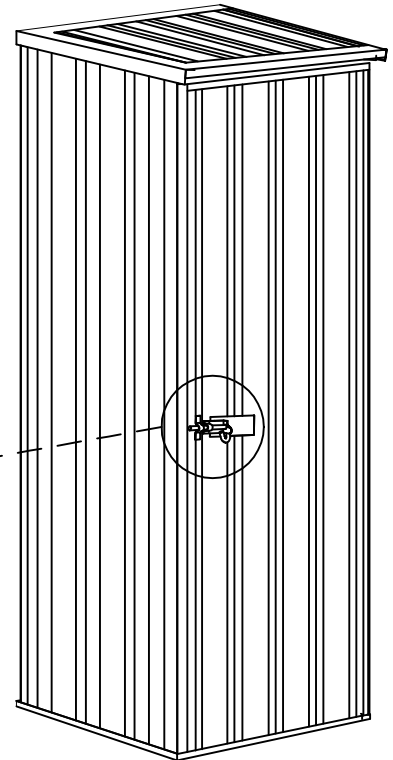
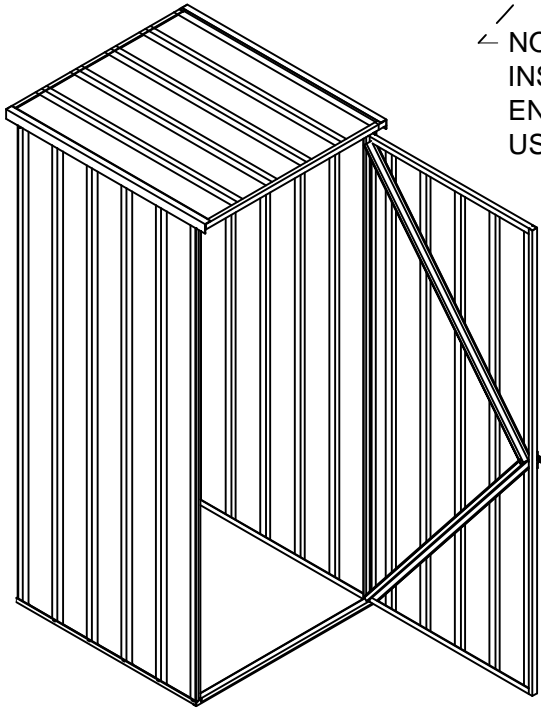

NOTE: The two holes required to connect the padbolt hasp for each door have not been pre-punched, to allow for proper alignment. Position the hasp centrally over the padbolt shaft, and drill 3mm holes and secure with screws.

AUSTRALIA PRODUCT WARRANTY AGAINST DEFECTS

Congratulations on your purchase of an ABSCO SHED

ABSCO SHEDS, including garden sheds, garden beds, aviaries, storage units, garages, awnings and carports are made using high quality Australian made steel.

We are pleased to advise we warrant that the steel coating will not rust, crack, flake peel or blister for 20 years from date of purchase, when installed within Australia.

This warranty does not apply to surface deterioration of panels caused by "Swarf" (Tiny particles of steel debris left from cutting, grinding or drilling operations) that has not been removed after building construction, or as a result of contact with damp soil, chemicals, fertilisers or other corrosive substances.

This warranty covers any Absco product used for normal domestic use and installed in accordance with the installation instructions. The warranty does NOT cover Damage caused by storms, wind, rain snow or poor foundations.

This warranty does NOT cover ABSCO products installed in severe coastal, industrial or other highly corrosive environments. The warranty does not cover fasteners (screws, nuts, bolts, rivets, hasps or bolts).

The warranty is limited to replacement and delivery of components and does not include any labour or installation costs. The benefits given by the warranty are in addition to your other rights and remedies under a law in relation to the goods or services to which the warranty relates.

The warranty applies to the exclusion of all other representations, guarantees or warranties express or implied, our goods come with guarantees that cannot be excluded under the Australian consumer law and is not transferable. You are entitled to a replacement or refund for a major failure and for compensation for any other foreseeable loss or damage. You are also entitled to have the goods repaired or replaced if the goods fail to be of an acceptable quality and the failure does not amount to a major failure. For further information go to <http://www.consumerlaw.gov.au>.

Please retain a proof of purchase (sales docket or invoice) or register your warranty within 30 days of purchase here: www.absco.com.au/register_warranty.php

In the unlikely event a warranty claim is made, it must be supported by photographic evidence and details of the defect, including component part numbers, together with proof of purchase documentation (or on-line registration of purchase) and forwarded to the address below. Upon receipt of the warranty claim, the Customer Service Manager will contact you within three business days to advise you of the assessment outcome of the claim, which may include your expenses incurred in making the claim.

THE CUSTOMER SERVICE MANAGER, ABSCO INDUSTRIES, PO BOX 119 ACACIA RIDGE QLD AUSTRALIA 4110

PHONE: 1800 029701 FAX: 07-33441191 EMAIL: warranty@absco.com.au

Issued 01 January 2012

ABSCO SHEDS - STORAGE GUIDELINES

ABSCO SHEDS include garden sheds, garden beds, storage units, aviaries, garages, awnings and carports.

ABSCO SHEDS are designed to be weatherproof for normal weather conditions. In the event of extreme weather conditions such as heavy rain, combined with high wind gusts, the ridge capping, sheeting joints, screw fixings etc., may exhibit minor deformations which may allow some water entry. These areas should be checked regularly to ensure that maximum strength and protection is maintained.

Other weather conditions such as extreme heat and extreme cold, moist or dry air can influence the effects of concrete floor moisture and/or condensation on the underside of the roof sheets.

ABSCO SHEDS and storage units are primarily used for storage of garden equipment such as lawnmowers, wheelbarrows, garden tools etc. Storage items that might be adversely affected by any of the above conditions may require additional protection such as being sealed or covered by plastic sheets and/or stacked above the concrete floor on timber slats.

Waterproof sealants may be used to offer further protection where required around joints and screw fixings, as can rubber door seals and other products which are available from most hardware outlets.

Placement of waterproof sealants (silicone) between the base of the shed and concrete slab is not recommended, as this process can have a reverse effect, preventing excess water from escaping, resulting with water accumulating and being trapped inside the shed.

Absco accepts no responsibility for water entry, floor moisture, condensation or the condition of the Contents inside your Absco steel building arising from any of the pre-mentioned weather conditions.